

EQ650

Box Type Color Camera with Wide Dynamic Range



Features

- 1/3" Sony Vertical Double Density Chip
- 550 TVL of horizontal resolution
- On screen display
- Wide dynamic range to eliminate washed out images from window glares
- Turn WDR On & Off with Auto Sensing feature
- Low light high sensitivity of 0.001 Lux with Digital Slow Shutter (DSS) technology
- Dual Voltage
- Suitable for any indoor surveillance with extreme lighting conditions

Specifications

Pickup Device	1/3" Sony Vertical Double Density CCD
Effective Pixels	768 x 494 (NTSC) / 752 x 582 (PAL)
Electronic Shutter	1/50 (1/60) ~ 1/100,000 sec.
Scanning System	2:1 Interlace
Video Output	BNC 1.0 Vp-p, 75 ohm
Horizontal Resolution	550 TVL
OSD Menu	Yes
Gamma Correction	0.45
S/N Ratio	Over 48dB (AGC Off / DSS Off)
AGC	MIN/AWT/MAX
Functions	Privacy Zones, Freeze, Image Reverse, Motion Detection
Sensitivity	0.001 Lux (DSS) 1.0 Lux / 30 IRE @ F2.0
Wide Dynamic Range	Auto/Off/On (Dynamic Range x64)
Backlight Comp.	Off/On Level Adjustment, Area Selection
White Balance	White Balance ATW/Push/Push Lock/User
Digital Slow Shutter	1 ~ 500 Field
Flickerless	Off/On (WDR On)
Sync. Mode	Internal/Line Lock
Power Source	DC12V/24VAC
Power Consumption	12VDC: 680mA max., 24VAC: 8.6W max.
Operating Temperature	-10°C ~ +45°C / 14°F ~ 113°F
Storage Humidity	30% ~ 90%
Dimensions (L x W x H)	115 x 65 x 59 mm / 4.5" x 2.6" x 2.3"
Weight	0.27 kg / 0.6 lbs.
Lens Type	C/CS Mount

Dimensions

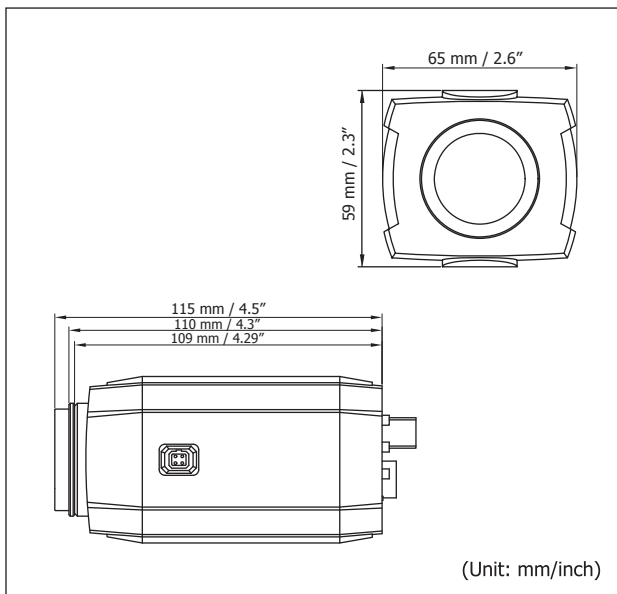

Ordering Information

- **EQ650:** Indoor Box Camera with Wide Dynamic, 550 TVL